

- NOTES:
SPECIFICATION:
1. CURRENT RATING: 3.0A MAX
 2. VOLTAGE: 100 VAC
 3. TEMPERATURE RANGE: -30 °C ~ 85 °C
 4. CONTACT RESISTANCE: 40 MILLIONHM MAX
 5. INSULATION RESISTANCE: 100 MEGOHMS MIN.
 6. LNSERTION FORCE : 5N~20N
 7. UNMATING FORCE: 8N~20N

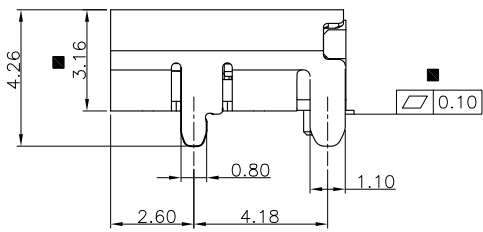

電鍍規格: 01FS16 $\frac{SX}{A}$ N201RZL
 A: Plating
 S1-03u*Min.gold in contact area/
 100u*Min.Tin in solder area.
 S2-05u*Min.gold in contact area/
 100u*Min.Tin in solder area.
 S3-gold flash in contact/
 100u*Min.Tin in solder area.
 S4-10u*Min.gold in contact area/
 100u*Min.Tin in solder area.
 S5-15u*Min.gold in contact area/
 100u*Min.Tin in solder area.
 S6-30u*Min.gold in contact area/
 100u*Min.Tin in solder area.

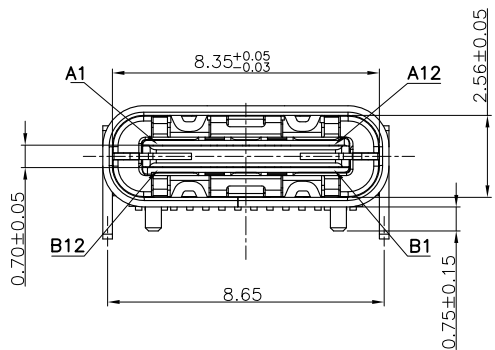
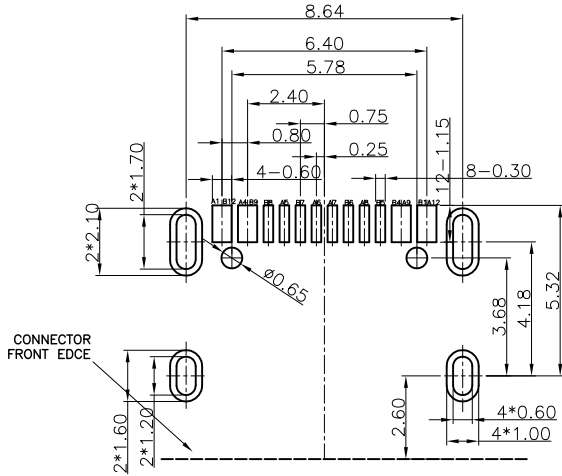
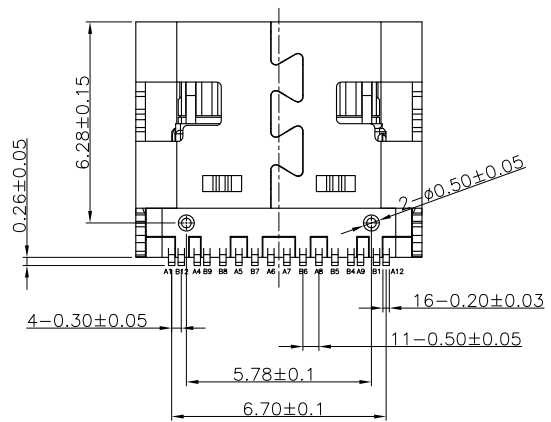

A1	GND	B12	GND
A4	VBUS	B9	VBUS
A5	CC1	B8	SBU2
A6	DP1	B7	DN2
A7	DN1	B6	DP2
A8	SBU1	B5	CC2
A9	VBUS	B4	VBUS
A12	GND	B1	GND
PIN	SIGNAL NAME	PIN	SIGNAL NAME

RECOMMENDED P.C.B. LAYOUT
 TOLERANCE UNSPECIFIED ±0.05mm 重点标注

Coorle 库乐科技

General Tolerance	.X	±0.30	DRAW	繪圖員		
	.XX	±0.20		DESIGN	設計	
	.XXX	±0.10		CHECK	校閱	
Angle Tolerance	.X°	±1.0°	APPRO.	承認		
	.XX°	±0.5°				
	.XXX°	±0.2°				
工程變更通知單號 ECN(DCN) NO.	版次 REV	日期 DATE	說明 DESCRIPTION	改變 CHANGE	承認 APPRO.	
	A	15'/09/05	NEW	梁祖传	金俊林	

名稱	USB 3.1 C TYPE 母头 L=7.3 单排				
TITLE:	16PIN SMT 四脚插板 有柱				
料號 PART NO.	USB16S-31-F001-A				
圖號 DWG. NO.	ZY-20150902-01				
SCALE	1:1	UNIT:mm	A4	⊕	SHEET: 1 of 1